

Internal gear pump

Type PGH.-3X

RE 10227-B/07.09

Replaces: 03.08

Material No. R901216585

Operating instructions

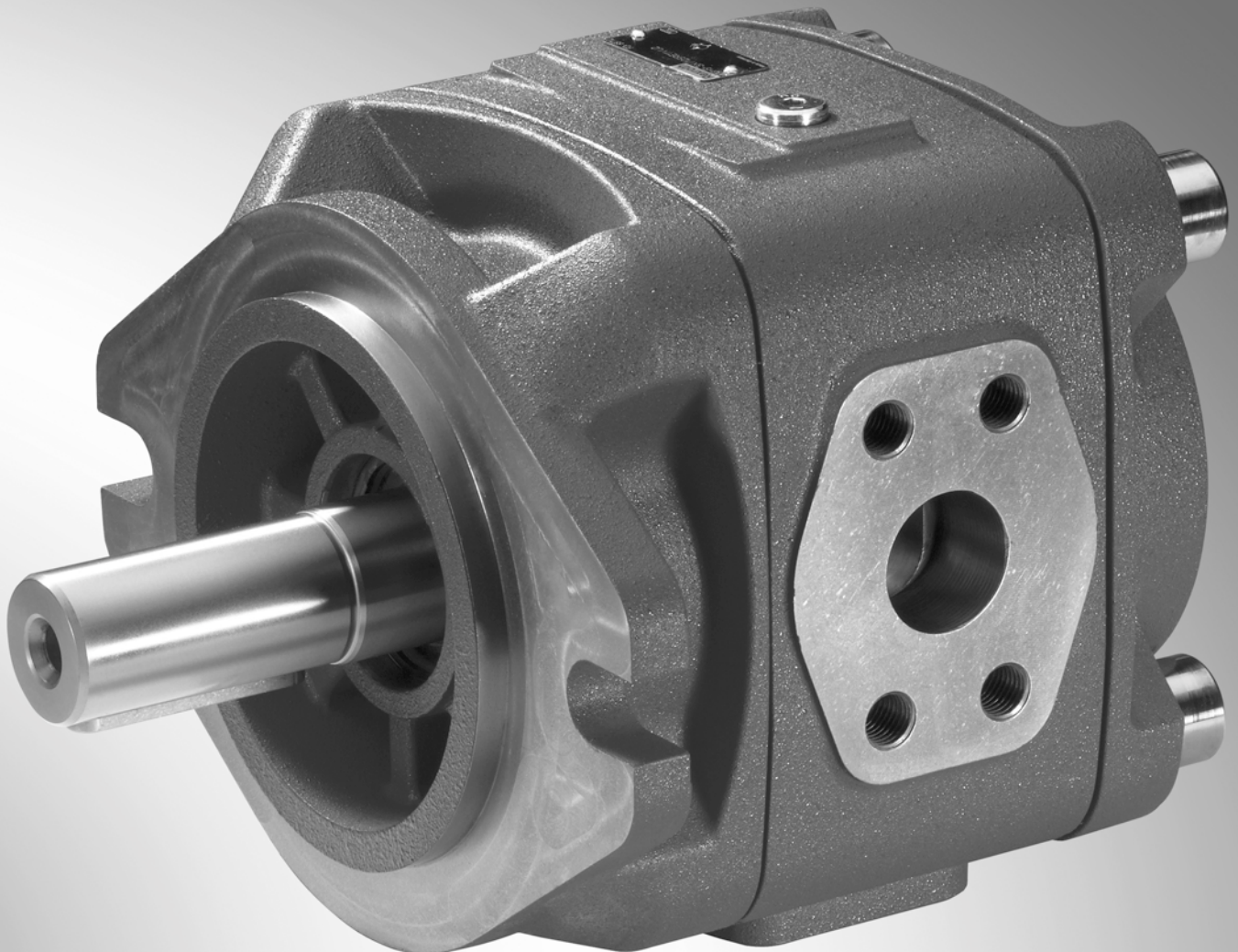

The data specified above only serve to describe the product. No statements concerning a certain condition or suitability for a certain application can be derived from our information. The information given does not release the user from the obligation of own judgment and verification. It must be remembered that our products are subject to a natural process of wear and aging.

© This document, as well as the data, specifications and other information set forth in it, are the exclusive property of Bosch Rexroth AG. It may not be reproduced or given to third parties without its consent..

The original operating instruction was prepared in German.

Inhalt

1	About this document	5
1.1	Related documents	5
1.2	Abbreviations used	5
1.3	Signs and symbols used	6
2	General safety instructions	7
2.1	Intended use	7
2.2	Improper use.....	7
2.3	Personnel qualifications	8
2.4	Adhere to the following instructions	8
2.5	Operator's obligations	10
3	Delivery contents	11
4	Product description	12
4.1	Device description.....	12
4.2	Identification of the internal gear pump.....	13
5	Transport and storage	14
5.1	Transporting the internal gear pump.....	14
5.2	Storing the internal gear pump.....	16
6	Assembly	17
6.1	Unpacking	17
6.2	Installation conditions.....	17
6.3	Required tools.....	17
6.4	Assembling the internal gear pump	18
7	Commissioning	21
7.1	Preparation commissioning.....	21
7.2	First commissioning	22
7.3	Re-commissioning after standstill	23
8	Operation	24
9	Maintenance and repair	25
9.1	Maintenance	26
9.2	Spare parts	27
10	Decommissioning	27
11	Disassembly and replacement	28
11.1	Required tools.....	28
11.2	Preparing disassembly.....	28
11.3	Disassembling the internal gear pump.....	28
12	Disposal	29
12.1	Environmental protection	29
13	Extension and conversion	29
14	Troubleshooting	30
14.1	How to proceed for troubleshooting	30
14.2	Malfunction table.....	31
15	Technical data	34
16	Appendix	34
16.1	Address directory	34

1 About this document

This instruction contains important information on the safe and appropriate assembly, transport, commissioning, maintenance, disassembly and simple troubleshooting of the internal gear pump PGH.-3X.

Read this instruction completely, especially chapter 2 “General safety instructions” before working with the internal gear pump PGH.-3X.

1.1 Related documents

The internal gear pump PGH.-3X is a system component.

Also observe the instructions of the other system components and the documentation of the system manufacturer.

Also observe the following instructions:

Table 1: Related documents

Documentation	Contents
Data sheet RE 10227	Technical data, operating conditions, performance limits, project planning information on internal gear pumps type PGH.-3X
Data sheet RE 07008	General information on hydraulic products
Data sheet RE 07900	General information on assembling, commissioning and maintenance of hydraulic systems
Data sheet RE 90220	General information on hydraulic fluids on mineral oil basis

Also observe the generally applicable, legal or otherwise binding regulations of the European or national legislation and the rules for the prevention of accidents and for environmental protection applicable in your country.

1.2 Abbreviations used

Table 2: Abbreviations

Documentation	Contents
PGH.-3X	Internal gear pump, fixed displacement
RE	Rexroth document in German
RX	Rexroth document in another language

About this document

1.3 Signs and symbols used

In this instruction, the following signs and symbols are used:

- ▶ Activity symbol: The text following this symbol describes activities that may be performed in any order.
- 1. Numbered activities: The text following these numbers describes activities that must be performed in the order of the numbering.
The indented text after activities/an activity describes their/its result.

- Item 1st category
 - Item 2nd category



This pictogram marks notes and tips. The text contains useful information that you should observe as it improves the operating procedure or is required as background information!

Safety instruction

In this instruction, there are safety instructions before the steps whenever there is a risk of personal injury or damage to the equipment. The measures described to avoid these hazards must be observed.

Safety instructions are set out as follows:

SIGNAL WORD!







Type of risk

- Consequences
- ▶ Precautions

- **Safety sign (warning triangle):** Draws attention to the risk
- **Signal word:** Identifies the degree of hazard
- **Type of risk:** Identifies the type or source of the hazard
- **Consequences:** Describes what occurs when the safety instructions are not complied with
- **Precautions:** States how the hazard can be avoided

The signal words have the following meaning:

Signal word	Application
DANGER! 	Indicates an imminently hazardous situation which, if not avoided, will certainly result in death or serious injury.
WARNING! 	Indicates a potentially hazardous situation which, if not avoided, could result in death or serious injury.
CAUTION! 	Indicates a potentially hazardous situation which, if not avoided, could result in minor or moderate injury or damage to equipment.
	If this information is disregarded, the operating procedure may be impaired.

2 General safety instructions

The internal gear pump PGH.-3X was manufactured according to the generally accepted rules of technology. There is, however, still a risk of personal injury or damage to equipment if the following general safety instructions and the warnings before the steps contained in these instructions are not complied with.

- ▶ Read these instructions completely and thoroughly before working with the PGH.-3X internal gear pump.
- ▶ Keep these instructions in a location where they are accessible to all users at all times.

2.1 Intended use

Internal gear pumps from Rexroth are intended for the set-up of hydraulic drive systems, particularly in mechanical engineering and plant and power unit construction. The PGH.-3X internal gear pump is intended exclusively for being integrated in a machine or installation or for being assembled with other components to form a machine or system.

In the project planning, the principles of the EU Machine Directive or comparable locally applicable provisions outside the EU are to be observed.

The product may be commissioned only if it is integrated in the machine/system for which it is designed and after it has been determined that the machine/system meets the specifications of the machine directive.

Internal gear pumps of type PGH.-3X must not be used in explosive environments according to directive 94/9/EC (ATEX).

Observe the technical data, operating conditions, and performance limits specified in the data sheet RE 10227.

Except the modifications described in chapter 13 "Extension and conversion", no modifications must be implemented to the pump, otherwise the warranty will become null and void!

Repair works must only be implemented by the manufacturer or authorized dealers and offices of the same. If you carry out repairs on your own, the warranty claim will forfeit.

The internal gear pump PGH.-3X is work appliance and not designed for private use.

Intended use includes having read and understood these instructions, especially the chapter 2 "General safety instructions".

2.2 Improper use

Any use of the internal gear pump PGH.-3X other than described in chapter "Intended use" is considered as improper.

General safety instructions

2.3 Personnel qualifications

Assembly, commissioning, disassembly, service (including maintenance and repair) require basic mechanical and hydraulic knowledge, as well as knowledge of the appropriate technical terms. In order to ensure operating safety, these activities may therefore only be carried out by qualified technical personnel or an instructed person under the direction and supervision of qualified personnel.

Qualified personnel are those who can recognize possible hazards and institute the appropriate safety measures due to their professional training, knowledge, and experience, as well as their understanding of the relevant conditions pertaining to the work to be done. Qualified personnel must observe the rules relevant to the subject area.

2.4 Adhere to the following instructions

General instructions

- Observe the locally regulations for accident prevention and environmental protection.
- Exclusively use products of Bosch Rexroth AG in good technical order and condition.
- Check the product for visible defects, for example transport damages, damaged or missing cover caps and/or shaft protection.
- Basically, you must not modify the internal gear pump PGH.-3X or install respectively convert the same in any other way differing from what is mentioned in chapter 13 "Extension and conversion".
- Only use the internal gear pump PGH.-3X within the performance range provided in the technical data.
- Persons who assemble, operate, disassemble or maintain products of Bosch Rexroth AG must not consume any alcohol, drugs or pharmaceuticals that may affect their ability to respond.
- The internal gear pump PGH.-3X considerably heats up during operation. Allow the internal gear pump PGH.-3X to cool down sufficiently before touching it. If this is not possible, wear heat-protective gloves or other protective clothing, e.g. gloves.
- The warranty only applies to the delivered configuration.
- The warranty will not apply if the product is incorrectly assembled or handled or not used as intended.
- Ensure that after the transport, the internal gear pump is put down safely and secured against unintended fall-down.
- Do not expose the product to any mechanical loads under any circumstances.:
 - Do not place any objects on it.
 - Never use the product as a handle or step.
 - Do not introduce further loads.

During transport

- During transport, pumps may fall down. Due to their weight, there is thus the risk of serious injuries.
- When lifting pumps of frame sizes 4 and 5, there is the risk of health hazards due to their weight. Use the intended eyebolt and suitable lifting gear for transporting them.

General safety instructions

- During assembly**
- Make sure the relevant system component is not under pressure or voltage before assembling the pump. Protect the system component against being switched on. In doing so, observe the operating instruction and other technical documentation of the system.
 - Make sure that all sealings and caps of the connections are mounted correctly to ensure that they are leakproof and fluids and foreign bodies are prevented from penetrating the product.
 - When assembling, provide for absolute cleanness in order to prevent dirt from getting into the hydraulic lines and causing product wear or malfunctions.
 - Let the product acclimate itself for several hours before commissioning, otherwise water may condense in the housing.
 - Immediately absorb oil leaking during the assembly in order to avoid any slip hazard.
- During commissioning**
- Cover the manually opened bleed port by screwing in the G 1/4 screw plug contained in the scope of delivery. Due to missing optical differentiating factors, there is the risk of mix-up with thread size: 1/2-20 UNF.
 - Make sure that all hydraulic connections are either used or covered. Commission the product only if it is installed completely.
 - Always consult the operating instructions of the machine/system.
- During operation**
- Only authorized personnel is allowed to operate the setting mechanisms of the components or parts, under the proviso that the hydraulic system is used as intended.
 - Only allow persons who are authorized by the operator to access the system's direct operating area. This is also valid when the system is standing still.
 - In case of an emergency, fault or any other anomalies, switch the system off and protect it against being switched on again.
- During cleaning**
- Cover all openings with the appropriate protective equipment.
 - Never use solvents or aggressive detergents.
 - Only clean the product using a dry, lint-free cloth.
 - Do not use a high-pressure cleaner for cleaning.
- During maintenance and repair**
- Perform the prescribed maintenance work at the intervals specified in the operating instruction.
 - Make sure that no line connections, connectors or components are disconnected as long as the system is under pressure and voltage. Protect the system against being switched on.
 - After completion of the repair works, ensure that all ports and caps are covered properly.
 - Repairs at the internal gear pump PGH.-3X may only be performed by the manufacturer or their authorized dealers and branches. No warranty is accepted for independently performed repair works.
- Disposal**
- Dispose of the product in accordance with the locally applicable regulations.
 - Dispose of the hydraulic fluid in accordance with the locally applicable regulations and according to the safety data sheets for the hydraulic fluids.
 - In order to ensure environmentally compliant disposal of the product, observe the principle of material separation.

General safety instructions**2.5 Operator's obligations**

The operator of the Bosch Rexroth AG products is bound to provide for personnel training on a regular basis regarding the following subjects:

- Observation and use of the operating instruction and the legal regulations
- Intended operation of the product
- Observation of the instructions from the factory security offices and of the work instructions from the operator
- How to behave in case of emergency



Bosch Rexroth offers training support for special fields. You can find an overview of the training contents in the Internet under <http://www.boschrexroth.de/didactic>.

3 Delivery contents

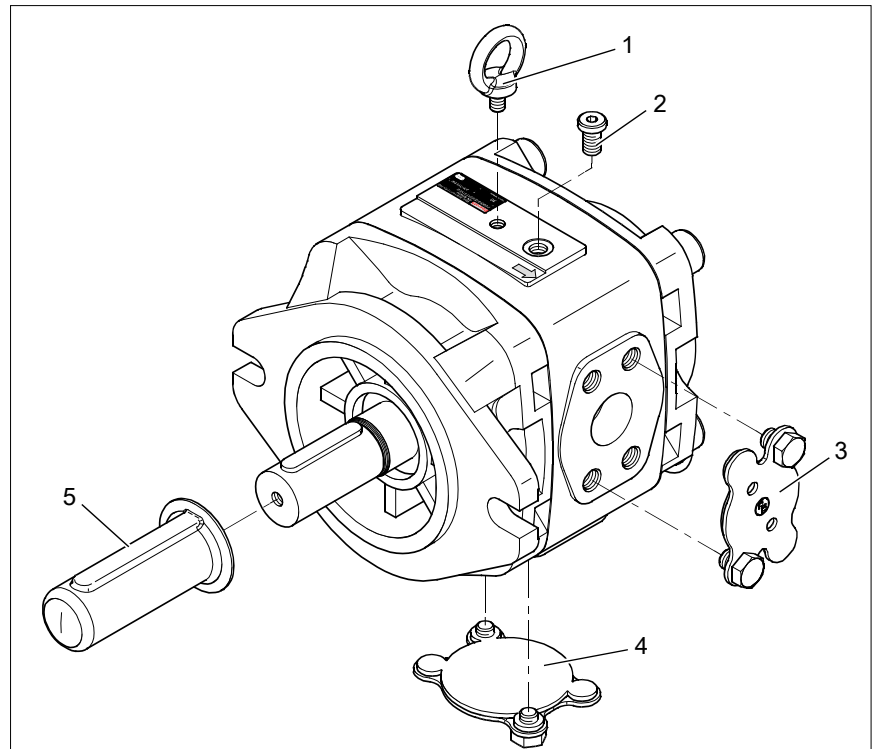

Fig. 1: Scope of delivery internal gear pump PGH.-3X

- | | | | |
|---|----------------------------------|---|----------------------------------|
| 1 | Ring bolt (eyebolt) | 4 | Flange cover
Suction port |
| 2 | Screw plug G 1/4 | | |
| 3 | Flange cover pressure connection | 5 | Protective plug shaft protection |

The delivery contents include:

- 1 internal gear pump PGH.-3X

Upon delivery, the following components are moreover assembled:

- Ring bolt (eyebolt)
- Screw plug G 1/4
- Flange cover pressure connection
- Flange cover suction port
- Protective plug shaft protection

Product description

4 Product description

For more detailed information on the operating conditions, port dimensions and performance limits refer to data sheet RE 10227.

4.1 Device description

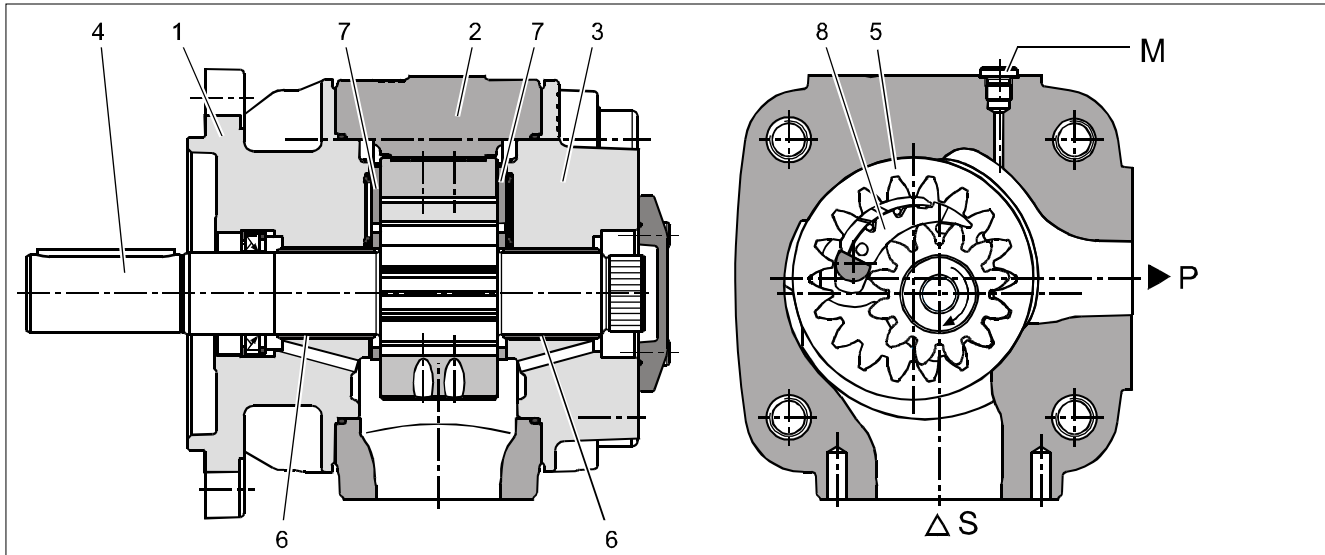

Fig. 2: Set-up of the internal gear pump

Hydraulic pumps of type PGH.-3X are gap-compensated internal gear pumps with fixed displacement.

They basically consist of: Mounting flange (1), housing (2), cover with through-drive (3), pinion shaft (4), internal gear (5), plain bearings (6), axial washers (7) and radial compensation (8).

They dispose of a suction port (S) and a pressure connection (P) as well as a measurement port (M) that is connected to the pressure channel.

4.2 Identification of the internal gear pump

The internal gear pump can be identified by means of its nameplate. The following example shows the nameplate of an internal gear pump PGH-3X:

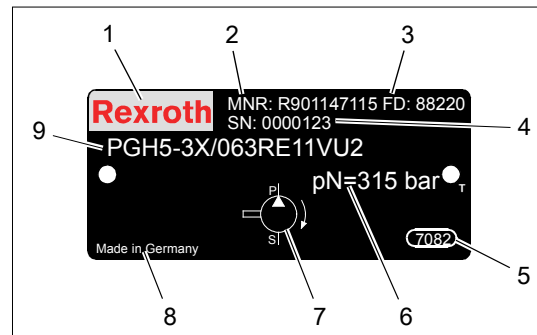

Fig. 3: Example nameplate internal gear pump

- | | | | |
|---|---------------------|---|------------------------------|
| 1 | Manufacturers | 6 | Rated pressure |
| 2 | Material number | 7 | Symbol according to ISO 1219 |
| 3 | Date of manufacture | 8 | Designation of origin |
| 4 | Serial number | 9 | Material short text |
| 5 | Area / works number | | |

5 Transport and storage

5.1 Transporting the internal gear pump

CAUTION!



Danger of health hazards!

When lifting pumps of frame sizes 4 and 5, there is the risk of health hazards due to their high weight.

- ▶ Use the eyebolt intended for transportation purposes and suitable lifting gear.

WARNING!



Crush injuries and fractures!

Pumps that are falling down may cause serious injuries.

- ▶ Use suitable lifting gear for lifting the pump.
- ▶ For lifting the pump, always use the enclosed eyebolt or a belt.
- ▶ Observe the prescribed position of the transport loops.

CAUTION!



Risk of damage!

The internal gear pump may be damaged by impact-like forces or shocks.

- ▶ Do not expose the product to any mechanical loads under any circumstances. Never use the product as a handle or step.
- ▶ Do not place any objects on it. Ensure that the internal gear pump is put down safely and secured against unintended fall-down.

Internal gear pumps can be transported using a fork lift or lifting gear.

- ▶ Ensure that the lifting gear's lifting capacity is sufficiently dimensioned in order to safely bear the pump's weight.

Weights

Table 3: Weights internal gear pumps

Frame size	PGH4					PGH5							
Size	20	25	32	40	50	63	80	100	125	160	200	250	
Weight kg	13.5	14	14.5	15	16	39	40.5	42.5	45	49	52.5	57.5	

The specified weight applies to the pump alone, possible attachments are not considered.

Transport with eyebolt You may hang the internal gear pump up at the eyebolt.

- ▶ Before the transport, check the tight seat of the ring bolt.
- ▶ Lift the internal gear pump as shown in fig. 4 using the screwed-in ring bolt without any risk of damage.

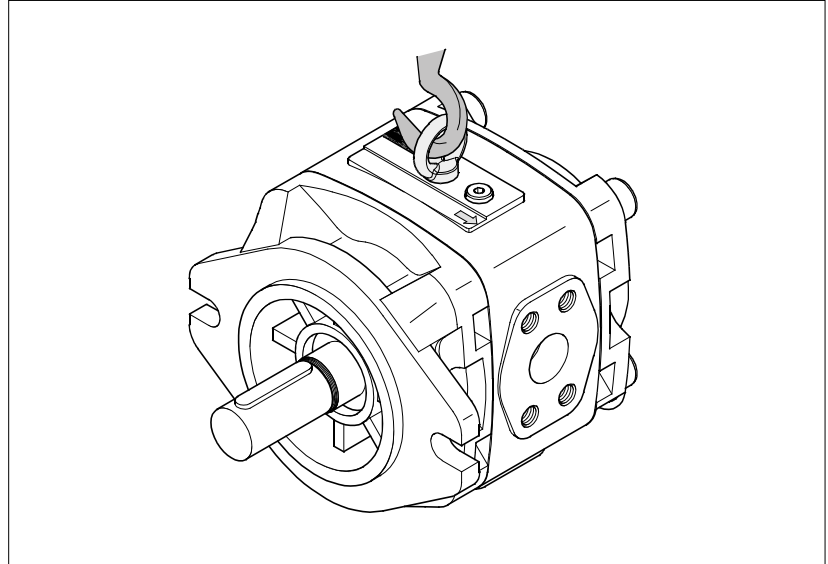

Fig. 4: Mounting using the ring bolt

Transport with belt

WARNING!



Risk of injuries!

The internal gear pump may tilt out of the transport loop and injure you.

- ▶ Hold the internal gear pump with the hand so that it does not tilt out of the loop.
 - ▶ Use the largest belt possible.
-
- ▶ Lay the belt around the internal gear pump so that it does not run over attachment parts (e.g. valves) and the internal gear pump is not lifted at the attachment parts.
Or lay the belt around flange and back cover in a way that the belt cannot slip off and the pump cannot tilt out.

Transport and storage

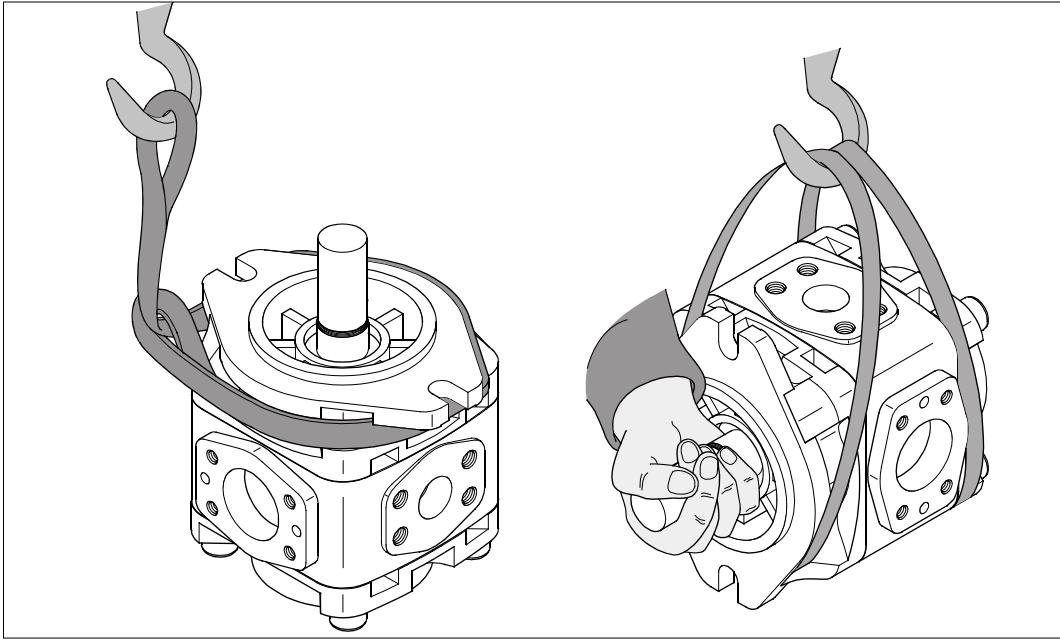

Fig. 5: Mounting using a belt

5.2 Storing the internal gear pump



Note that the warranty period is not extended by any storage!

Requirement

- The storage rooms must be free of etching substances and gases.
- The storage rooms must be dry.
- The perfect storage temperature lies between +5 °C and +20 °C.
- The temperature should be as constant as possible.
- Avoid high light irradiation.

Maximum storage time

The maximum storage time is 24 months.

Storage up to 9 months

- ▶ Leave the internal gear pump in its delivery condition (dampened with mineral oil).

Storage up to 24 months

- ▶ Fill the internal gear pump with mineral oil.

Commissioning after storage

Procedure after expiry of the maximum storage time:

- ▶ Before assembling, check the complete internal gear pump for damage and corrosion.
- ▶ Perform a test run to check the internal gear pump for function and leak-tightness.
- ▶ Exchange the shaft sealing ring in case the storage time of 24 months is exceeded.



After expiry of the maximum storage time, we recommend to subject the internal gear pump to a precautionary inspection and to have the seals exchanged by a responsible Rexroth service!

6 Assembly

You may only start with the assembling if the hydraulic scheme of the system is readily available.

6.1 Unpacking

CAUTION!



Danger of parts that are falling down!

In case of improper opening of the packaging, the internal gear pump may fall out and cause injuries or damage.

- ▶ Put the packaging on a level, bearing surface.
 - ▶ Open the packaging only from the top.
-
- ▶ Open the packaging of the internal gear pump.
 - ▶ Take out the internal gear pump using suitable lifting gear.
 - ▶ Dispose of the packaging in accordance with the locally applicable provisions.

6.2 Installation conditions

- Cleanness** It is imperative to provide for absolute cleanliness. The pump and all other components used must be clean when they are assembled. Contamination of the hydraulic fluid may considerably impair the internal gear pump's service life.
- Cleaning** Use lint-free, dry cleaning cloths for cleaning.
- Temperature** The temperature of the internal gear pump must comply with the ambient temperature of the place of assembling. Give the pump enough time to adjust to the temperature conditions.
- Filling** Before the assembling of the internal gear pump, remove fluids that might have been filled in for storing the pump.

6.3 Required tools

For information regarding the required tools and the tightening torques of the mounting screws, refer to the machine and system manufacturer.

6.4 Assembling the internal gear pump

CAUTION!



Risk of damage to persons and property!

Assembly of the internal gear pump requires basic mechanical and hydraulic knowledge.

- ▶ The assembly of the internal gear pump may only be performed by qualified personnel (see “Personnel qualifications” in chapter 2 “General safety instructions”).

DANGER!



Slip hazard!

Slipping may cause serious injuries. When removing shaft protection, protective plugs and flange covers, residual oil may leak at zero pressure.

- ▶ Immediately absorb leaking residual oil.

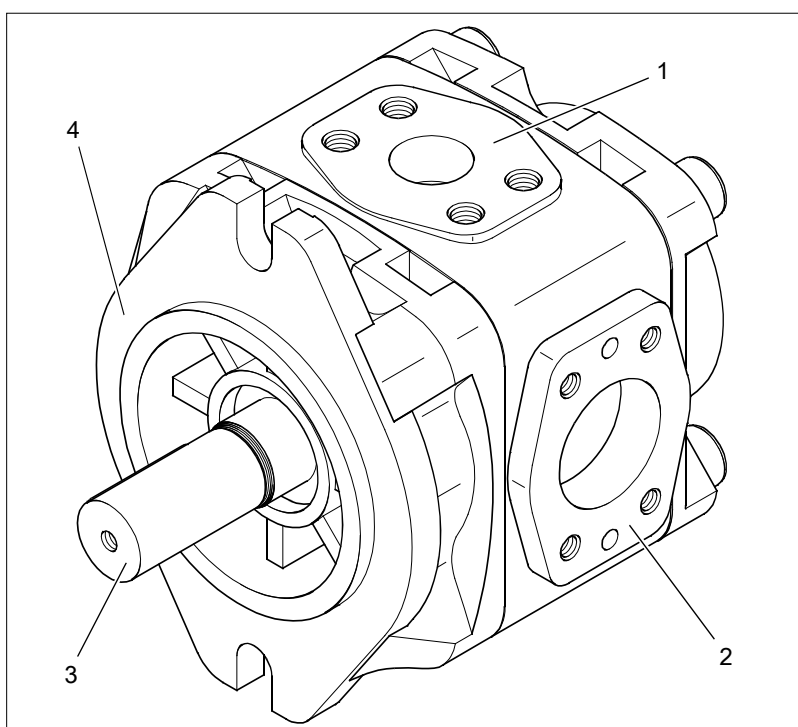

Fig. 6: Assembly internal gear pump PGH.-3X

- | | |
|---------------------------|-------------------|
| 1 Pressure connection “P” | 3 Shaft |
| 2 Suction port “S” | 4 Mounting flange |

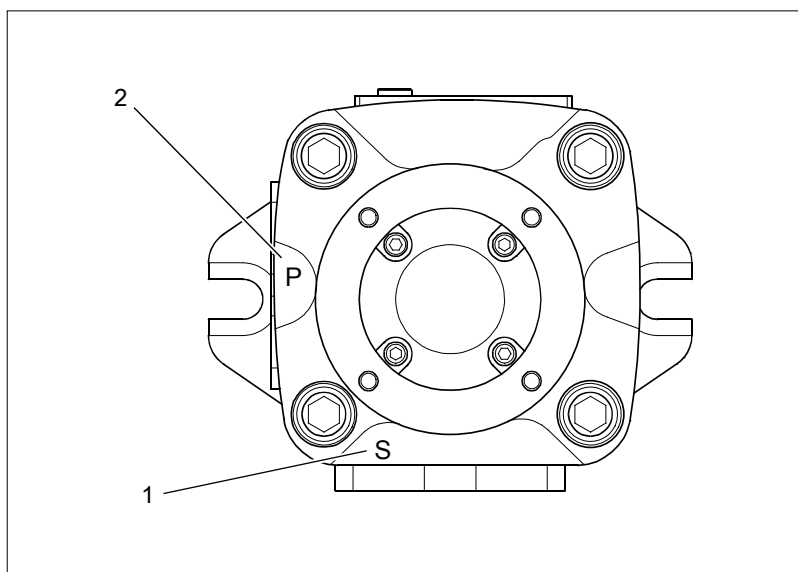

Fig. 7: View housing with marking pressure and suction port

- 1 Marking suction port "S"
- 2 Marking pressure connection "P"

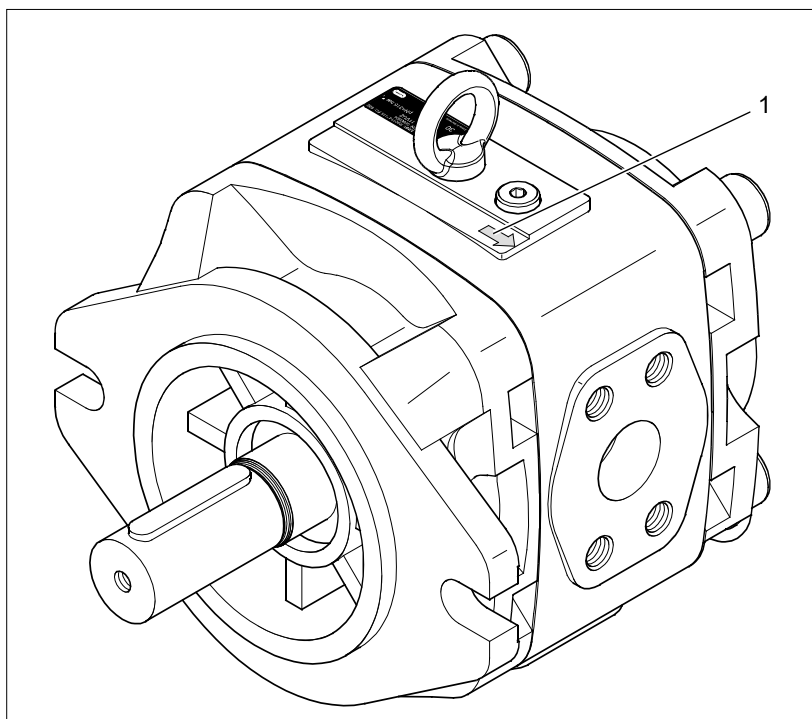

Fig. 8: Assembly internal gear pump PGH.-3X

- 1 Arrow indicating the direction of rotation on the housing

Assembly

For assembling the internal gear pump, the following work steps are required:

- Assembling the coupling**
- ▶ Make sure that the direction of rotation of the internal gear pump according to the arrow indicating the direction of rotation on the housing complies with the direction of rotation of the electric motor.
 - ▶ Remove the protective plug at the shaft.
 - ▶ Slightly grease the shaft end and the coupling halves.
 - ▶ Push the first coupling half onto the shaft end.
 - ▶ Align the coupling half axially, according to the manufacturer's specifications.
 - ▶ Fix the coupling half on the shaft.
 - ▶ Check whether the position of the coupling half corresponds to the manufacturer's specifications and adjust it, if necessary.
 - ▶ Screw the pump carrier to the mounting flange.
 - ▶ Grease the motor shaft and its coupling halves.
 - ▶ Push the second coupling half onto the motor shaft.
 - ▶ Align the coupling half on the motor shaft.
 - ▶ Fix the coupling half on the motor shaft.
 - ▶ Attach the gear rim or other elastic coupling components to the motor shaft coupling half.
 - ▶ Put the pump onto the pump carrier attached to the motor shaft and mount the pump.
 - ▶ Check the required coupling play pump / motor and adjust it, if necessary. For the coupling play, refer to the specifications of the coupling manufacturer.
 - ▶ When using elastic couplings, check the drive for the absence of resonance after completion of the installation.

- Hydraulic connection of the pump**
- ▶ Remove the flange covers at suction and pressure connection.
 - ▶ Check the lines for cleanliness.
 - ▶ Ensure that the line connection comprises the intended seals.
 - ▶ If necessary, secure O-rings against slipping using assembling grease.
 - ▶ Now, establish the hydraulic connections of the pump according to the specifications of the system or machine manufacturer.

7 Commissioning

For commissioning the internal gear pump PGH.-3X, the operating instruction of the hydraulic system must necessarily be observed.

DANGER!



Risk of damage to persons and property!

Assembly of the internal gear pump requires basic mechanical and hydraulic knowledge.

- ▶ The assembly of the internal gear pump may only be performed by qualified personnel (see "Personnel qualifications" in chapter 2).

CAUTION!



Risk of damage to persons and property!

If the internal gear pump PGH.-3X has not been assembled correctly, persons could be injured and the product or the system could be damaged when commissioning the internal gear pump.

- ▶ Make sure that the internal gear pump has been assembled correctly by qualified personnel before commissioning the internal gear pump.

CAUTION!



Material damage!

Contaminated hydraulic fluid could result in wear and tear and malfunctions. In particular foreign bodies like e.g. welding beads and metal cuttings in the suction line may damage the internal gear pump.

- ▶ When commissioning the product, provide for absolute cleanliness.
- ▶ Make sure that no contamination may penetrate when sealing the measuring connections.

CAUTION!



Material damage!

If you commission the internal gear pump without or with insufficient hydraulic fluid, the internal gear pump will be damaged immediately or even destroyed.

- ▶ When commissioning or re-commissioning a machine and/or system make sure that the suction and pressure lines of the internal gear pump are filled with hydraulic fluid and remain filled also during operation.

7.1 Preparation commissioning

- ▶ Ensure that the suction channel is free.
- ▶ Ensure that the piping has been assembled in a clean and tight form.
- ▶ Check the hydraulic scheme for direct functions/movements when pressure is set-up.
- ▶ Check the hydraulic fluid tank for cleanliness.
- ▶ Fill in the hydraulic fluid according to the specification of the system manufacturer. For this purpose, only use filters with the required minimum retention rate.
- ▶ Check the suction line for tight assembly.
- ▶ Make sure that the direction of rotation of the motor complies with the direction of rotation of the pump.

7.2 First commissioning

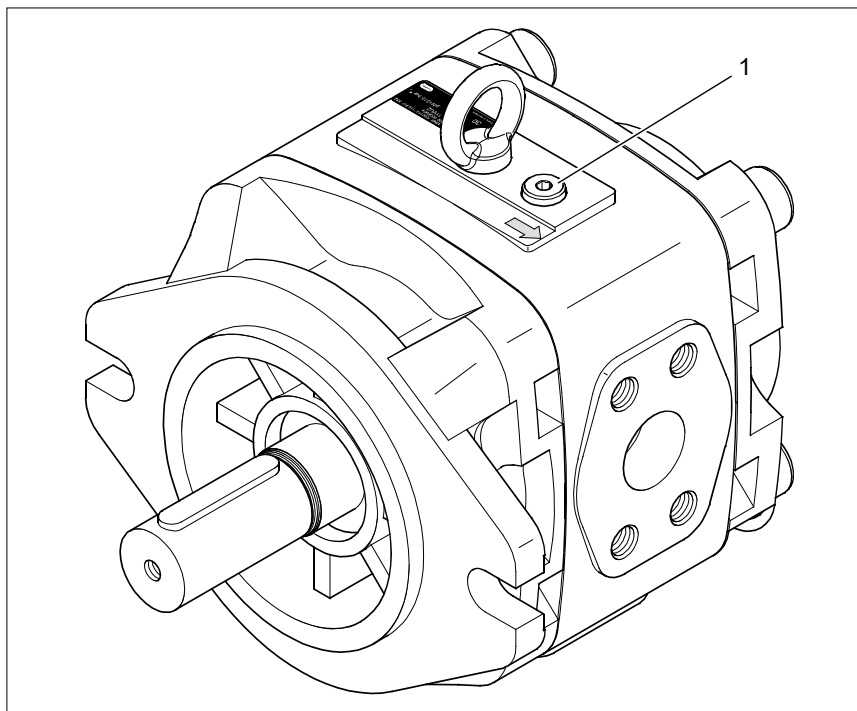

Fig. 9: Bleed and measurement port internal gear pump

1 Bleed port internal gear pump (M)

Proceed as follows to commission the internal gear pump PGH.-3X:

DANGER!



Slip hazard!

Slipping may cause serious injuries. When removing shaft protection, protective plugs and flange covers, residual oil may leak at zero pressure.

- ▶ Immediately absorb leaking residual oil.

WARNING!



Risk of intoxication and injury due to the leaking hydraulic medium!

Contact with hydraulic fluids causes health hazards (e.g. eye injuries, skin lesions, intoxication in case of inhaling).

- ▶ Before each commissioning, always check the lines for wear and/or damage.
- ▶ Wear protective gloves, protective goggles and suitable working clothes.
- ▶ Immediately consult a doctor if there is nevertheless contact between the hydraulic fluid and your eyes or your skin.

- ▶ Pre-fill the pump with filtered fluid. Depending on the installation position, filling can be performed via the suction, pressure or measurement port. For information regarding a suitable connection, please refer to the operating instruction of the system.
- ▶ Bleed the pump. For information on how to bleed the internal gear pump, please refer to the operating instruction of the system.
If no switchable or automatic bleeding is provided, you must bleed the pump manually.

Manual bleeding of the pump

As standard, the bleed and measurement port of the internal gear pump is closed by means of G 1/4 screw plug.

CAUTION!**Risk of damage to persons and property!**

If a screw-in stud is pressurized that with regard to the system of units and size does not correspond to the threaded hole, this may result in the automatic loosening or even the jumping out of the screw-in stud similar to a projectile. This may cause serious injuries and material damage. Hydraulic fluid may leak through this leakage point. Due to missing optical differentiating factors, there is the risk of mix-up with thread size: 1/2-20 UNF.

- ▶ Make sure that there are no mistakes in the assembling of the screw plug.
- ▶ For closing the bleed and measurement port, only use the supplied screw plug G1/4.

1. Open the bleed and measurement port by removing the screw plug or switch to depressurized circulation according to the system's operating instruction.
2. For bleeding the pump, switch the motor on shortly and immediately off again (jog mode). Repeat this procedure until the fluid leaks free from bubbles and complete bleeding is ensured.
3. Cover the manually opened bleed port by screwing in the G 1/4 screw plug. Tightening torque $T = 30 \text{ Nm}$.

Now, the internal gear pump is bled.

- ▶ Ensure that the system is depressurized.
- ▶ Switch on the drive motor and start-up the pump shortly until it reaches the maximum speed.
- ▶ Build up pressure slowly. In doing so, observe the instructions of the system manufacturer.
- ▶ When commissioning the system make sure that under high pressure, no fluid leaks.
- ▶ When commissioning the system make sure that no bubbles and/or foams are generated in the hydraulic fluid.
- ▶ Switch the motor off again.

7.3 Re-commissioning after standstill

- ▶ Upon re-commissioning after disconnection from supply, check the direction of rotation of the electric motor for compliance with the arrow indicating the direction of rotation on the pump housing.
- ▶ Inspect pump and system for leakage. Loss of oil indicates leakage below the hydraulic fluid level. An increased hydraulic fluid level in the tank indicates leakage above the hydraulic fluid level.
- ▶ When the pump is arranged above the hydraulic fluid level, the pump can drain via leakage, e.g. a worn-out shaft sealing ring. In this case, it must be bled again during re-commissioning. Have the damage repaired.
- ▶ Switch on the motor if the system is flawless.

8 Operation

The internal gear pump PGH.-3X may only be commissioned with the admissible data, see Technical Data Sheet "Internal gear pump, fixed displacement" RE 10227.

The pump may only be operated in perfect condition.

In order to provide for a long and reliable operation of the internal gear pump, Bosch Rexroth AG recommends to check the hydraulic system and the internal gear pump at regular intervals:

- Continuously monitor noises, vibrations and temperatures.
- After some operating time, check the hydraulic fluid in the tank for bubble or foam formation at the surface.

During operation, pay attention to changes in the noise characteristic. Due to the heating of the operating medium, slightly increasing noises are normal. Considerably increasing noises or short-term and irregular noise changes may be an indication of the aspiration of air. If the suction line opening is located too closely under the surface of the hydraulic medium, air can also be aspirated via a vortex.

Changes in operating speeds, temperatures, the power consumption or increasing noises are an indication of wear or damage at the system or the pump.

9 Maintenance and repair

DANGER!



Risk of damage to persons and property!

Maintaining and repairing the internal gear pump requires basic mechanical and hydraulic knowledge.

- ▶ Only qualified personnel (see "Personnel qualifications in chapter 2) is authorized to perform the maintenance and the repair of the internal gear pump.

CAUTION!



Any dirt or fluids penetrating the device lead to malfunctions!

Safe function of the system/the components is no longer ensured.

- ▶ Always provide for absolute cleanness when working on the hydraulic system.
- ▶ Do not use a high-pressure cleaner.
- ▶ Before commissioning the internal gear pump, ensure that the internal gear pump has been assembled correctly by qualified personnel.

CAUTION!



Risk of damage to persons and property!

Aggressive detergents may damage the seals of the internal gear pump and let them age faster.

- ▶ Never use solvents or aggressive detergents.

DANGER!



Risk of injuries when assembling under pressure!

Damages to the pump and risk of injuries in case of maintenance and repair works while the hydraulic system is pressurized.

- ▶ Depressurize and de-energize the system before starting any works at the pump.
- ▶ Before starting any works ensure that the system is depressurized.

DANGER!



Risk of injuries when assembling under voltage!

Damage of the pump or risk of injury in case of assembling with activated voltage supply.

- ▶ De-energize and discharge the system before starting any works.

Inspection	Check the leak-tightness of the lines, the line connections, and shaft seals. In doing so, observe the instructions of the system manufacturer.
Checking the warning devices	Check after completion of the maintenance and repair works whether all warning and protective devices have been re-applied and are in perfect condition.
Replacing wear parts	When replacing wear parts, use only original spare parts. For reasons of precaution, wear parts/plastic parts of the coupling should be exchanged after 5 years at the latest, even if they are not worn yet. In addition, observe the manufacturer's instructions.
Maintenance	Assembling, maintenance and repair works at the pump may only be performed by the manufacturer or their authorized dealers and branches. No warranty is accepted for independently performed repair works!
Closing openings	For the transport, close all openings with suitable cover caps/protection devices in order to prevent dirt or humidity from penetrating into the internal gear pump.

9.1 Maintenance

In order to provide for safe operation and long service life of the pump, a maintenance schedule has to be prepared for the aggregate, the machine or the system. The maintenance schedule must ensure that the operating conditions of the pump remain within the prescribed limits during the whole service life.

You must particularly ensure compliance with the following operating parameters:

- Required fluid cleanliness,
- Operating temperature range,
- Level of the operating medium.

Apart from that, the pump and the system must be checked for changes in the following parameters on a regular basis:

- Vibrations,
- Noise,
- Temperature difference pump - fluid tank,
- Foam formation in the tank,
- Leak-tightness.

Changes in these parameters are an indication of wear of components (for example drive motor, pump, coupling). The cause must be determined and remedied immediately.

For ensuring high operating safety of the pump in the machine/system, we recommend to check the parameters specified above continuously and automatically and to provide for the automatic shut-down in case of changes exceeding the usual fluctuations in the intended operating area.

Plastic components of drive couplings should be exchanged regularly, after 5 years, however, at the latest. The respective manufacturer's specifications are to be observed.

As preventative maintenance of the pump, we recommend to exchange the shaft sealing ring after an operating time of maximally 5 years by an approved Bosch Rexroth service operation.

For more information on the maintenance please refer to the system's operating instruction.

9.2 Spare parts

Repairs at the internal gear pump PGH.-3X may only be performed by the manufacturer or their authorized dealers and branches. No warranty is accepted for independently performed repair works. Authorized dealers and branches are available for performing repairs at their facilities.

In case of questions on spare parts and repairs, please contact your responsible Rexroth service or the service department of the manufacturer of the internal gear pump:

Bosch Rexroth AG
Service Industriehydraulik [Industrial hydraulics]
Competence Center Lohr
Bgm.-Dr.-Nebel-Str. 8
D-97816 Lohr am Main
Phone: +49 (0) 93 52 - 18 0
spareparts.bri@boschrexroth.de

The addresses of our sales and service network can be found at:
www.boschrexroth.com/adressen

10 Decommissioning

Information on de-commissioning the internal gear pump can be found in the operating instructions on the system.

11 Disassembly and replacement

11.1 Required tools

Disassembly of the internal gear pump PGH.-3X can be performed using standard tools.

You need:

- A set of Allen wrenches for the housing screws.
- Pull-off equipment for the fitting key at the cylindrical shaft end.
- A screwdriver, flat, for prying off the end cover and the housing.
- An oil tray and cloths for absorbing the residual oil.

11.2 Preparing disassembly

Decommission the overall system as described in the system's operating instruction.

Then prepare the disassembly of the internal gear pump as follows:

DANGER!**Slip hazard!**

Slipping may cause serious injuries. When removing shaft protection, protective plugs and flange covers, residual oil may leak at zero pressure.

- ▶ Immediately absorb leaking residual oil.

-
- ▶ Depressurize the pressure side (P line).
 - ▶ Ensure that the relevant system parts are depressurized and de-energized.

11.3 Disassembling the internal gear pump

In order to disassemble the internal gear pump, proceed as follows:

DANGER!**Slip hazard!**

Slipping may cause serious injuries. When removing shaft protection, protective plugs and flange covers, residual oil may leak at zero pressure.

- ▶ Immediately absorb leaking residual oil.

DANGER!**Risk of injuries when disassembling under pressure!**

Damages to the pump and risk of injuries in case of disassembly of the internal gear pump while the hydraulic system is pressurized.

- ▶ Depressurize the system before starting any works at the pump.
-

WARNING!**Crush injuries and fractures!**

Pumps that are falling down may cause serious injuries.

- ▶ Use suitable lifting gear for lifting the pump.
- ▶ For lifting the pump, always use the enclosed eyebolt or a belt.
- ▶ Observe the prescribed position of the transport loops.

1. Lock the pump's suction port. When doing so, observe the instructions of the system's operating instruction.
2. Disconnect the piping on the pressure side.
3. Loosen the mounting screws at the pump.

The pump is disassembled.

12 Disposal

When disposing of the internal gear pump, the following points are to be observed:

1. Drain the internal gear pump.
2. Disassemble the internal gear pump into its individual components in order to recycle them.
3. Separate:
 - Cast iron,
 - Steel,
 - Non-ferrous metal,
 - Seals.

12.1 Environmental protection

Careless disposal of the internal gear pump and of the hydraulic fluid can lead to contamination of the environment.

- ▶ Therefore dispose of the internal gear pump and the hydraulic fluid in accordance with the locally applicable regulations.
- ▶ Dispose of any hydraulic fluid residues according to the respective safety data sheets applicable to these hydraulic fluids.

13 Extension and conversion

Pump combinations

Internal gear pumps can be combined into multiple pumps using original Bosch Rexroth combination parts.

In doing so, the system's operating instruction must be considered.

For information regarding the assembling of the combination parts, please refer to the installation instruction of the respective combination part.

Pump combinations may only be installed by authorized experts.

Conversion

Any conversion of the internal gear pump is not admissible.

14 Troubleshooting

14.1 How to proceed for troubleshooting

Always act systematically and targeted, even under pressure of time. Random and imprudent disassembly and readjustment of settings might result in the inability to restore the original error cause.

First get a general idea of how your product works in conjunction with the entire system.

Try to find out whether the product has worked properly in conjunction with the entire system before the troubles occurred first.

Try to determine any changes of the entire system in which the product is integrated:

- Were there any changes to the product's operating conditions or operating range?
- Were there any changes or repair works on the entire system (machine/system, electrics, control) or on the product? If yes: Which?
- Was the product or machine used as intended?
- How did the malfunction appear?

Try to get a clear idea of the error cause. Directly ask the (machine) operator.

If you could not remedy the occurred fault, please contact one of the addresses you find under www.boschrexroth.com or:

Bosch Rexroth AG

Service Industriehydraulik [Industrial hydraulics]

Competence Center Lohr

Bgm.-Dr.-Nebel-Str. 8

D-97816 Lohr am Main

Phone: +49 (0) 93 52 - 18 0

14.2 Malfunction table

Table 4: Malfunction table internal gear pump PGH.-3X

Malfunction	Possible cause	Remedy
Pump does not deliver / suck	The pump is not bled	Bleed the pump
	O-rings defective (wrong medium, damage to the sealing, missing O-ring, wrong O-ring)	Install/replace with original O-ring
	Sealing surfaces contaminated or damaged	Ensure cleanness and integrity of the sealing surface
	Coupling is missing and/or parts of the coupling are missing	Amend the coupling or coupling component
	See malfunction "Wrong direction of rotation of the drive motor"	
	See malfunction "Air inlet through the output side"	
	See malfunction "Back pump is blocked"	
	See malfunction "Back elements exceed maximum torque"	
Delivery pressure too low	See malfunction "Inlet pressure <0.6bar"	
	See malfunction "Admissible level of contamination exceeded"	
	See malfunction "Output flow is not achieved"	
Pump is too loud	See malfunction "Interfaces not tight"	
	See malfunction "Wrong direction of rotation of the drive motor"	
	Ambient temperature is below -20 °C	Provide for suitable ambient temperatures
	Aspiration of air bubbles	Bleed the system
	Vortex generation in the suction area of the fluid tank	Check the filling level of the fluid tank
	See malfunction "Viscosity <10 mm ² /s"	
	See malfunction "Viscosity >300 mm ² /s"	
Interfaces not tight	O-rings defective (wrong medium, damage to the sealing, missing O-ring, wrong O-ring)	Use original O-ring
	Sealing surfaces contaminated or damaged	Ensure cleanness and integrity of the sealing surface
	Incorrect assembly (screws too long)	Assembly only by authorized, trained and instructed qualified personnel; only use original spare parts
	Combination part is not suitable	Observe the project planning information in RE 10227
Pressure peaks over >350 bar from system	Feedback from hydraulic system	In the project planning, observe the admissible pressure peak in RE 10227 Integrate pressure control valves
The system interfaces cannot be mounted	Wrong connection flanges/screws suction port and/or pressure connection selected	Observe the flange dimensioning in RE 10227
Viscosity <10 mm ² /s	Hydraulic fluid too hot	Information on hydraulic fluids in RE 90220; observe the project planning information in RE 10227; check the water content, viscosity, turbidity and smell on a regular basis
	Shelf life of the hydraulic fluid is exceeded	
	Wrong hydraulic fluid filled in	
Viscosity >300 mm ² /s	Fluid temperature too low	Information on hydraulic fluids in RE 90220; observe the project planning information in RE 10227; check the water content, viscosity, turbidity and smell on a regular basis
	Wrong hydraulic fluid filled in	
	Thickening due to mixing	

Troubleshooting

Malfunction	Possible cause	Remedy
Volumetric or mechanical efficiency is not achieved	See malfunction "Viscosity >300 mm ² /s"	
	See malfunction "Viscosity <10 mm ² /s"	
	See malfunction "Output flow is not achieved"	
	Operation projected with too low and/or too high speed	Observe the project planning information in RE 10227
	See malfunction "Admissible level of contamination of the hydraulic fluid exceeded"	
Admissible level of contamination of the hydraulic fluid has been exceeded	Mixing of different fluids	Observe the information on hydraulic fluids in RE 90220
	Fluid aging and abrasion from system	Check the fluid contamination according to the maintenance schedule
	Insufficient filtration	Observe the project planning information in RE 10227 and check according to maintenance schedule
Wrong direction of rotation of the drive motor	Unexpected inlet of contamination (e.g. in case of fluid exchange)	Provide for a clean environment, filling only via filter
	Drive motor corrected incorrectly	Assembling only by authorized, trained and instructed experts Check the direction of rotation in case of re-commissioning after mains separation
Protective motor switch is activated	Drive motor too weak	Observe the information on the required drive power in RE 10227
	See malfunction "Wrong connection of the drive motor"	
	See malfunction "Pump wear"	
Input speed too high/too low	Motor projected with too low and/or too high speed	Observe the project planning information in RE 10227
Air inlet through the output side	O-rings defective (wrong medium, damage to the sealing, missing O-ring, wrong O-ring)	Use the original combination part set, replace the seals
Fluid leakage	Tank hangs too high	Observe the project planning information in maintenance and commissioning of hydraulic components RE 07800 / RE 07900
	Fluid level too high	
	Pre-charged fluid tank (too high pressurized) and/or pre-filling pump	Observe the project planning information for pre-charged tank and/or pre-filling pump
	Defective seal	Exchange the damaged O-ring
	See malfunction "Interfaces not tight"	
Inlet pressure <0.6bar	Faulty dimensioning of the suction line (length, cross-sections, angle)	Observe the project planning information in RE 10227
	Speed too high	In the project planning, observe the maximum speed
	Foreign body in the suction channel	Remove the foreign body
	Air pressure too low (also tank without pressure compensation)	In the project planning, observe the absolute pressure
Inlet pressure >2bar	See malfunction "Fluid leakage"	
Output flow is not achieved	Pump sucks in air	Check the level in the fluid tank and correct it, if necessary Observe the information on the design of the lines in hydraulic trainer, volume 3 and project planning information
	Input speed too low	In the project planning, observe the characteristic curve average values drive power in RE 10227
	See malfunction "Admissible level of contamination of the hydraulic fluid exceeded"	
	See malfunction "Pump wear"	

Troubleshooting

Malfunction	Possible cause	Remedy
Permanent output pressure >315bar	Line cross-section too little	Observe the information on the design of the lines in hydraulic trainer, volume 3 and project planning information
	Flow resistances too high	
	Admissible load exceeded	For limiting the operating pressure and for the solenoid-actuated discharging of the operating pressure, install a pump safety block. In doing so, observe the information in RE 10227
Wear caused by radial force on the shaft	Incorrect installation	Observe the installation information
	Unsuitable parts	use only an original combination part set
	Tightening torque for the screws is too low	Observe the tightening torques in the installation information
	See malfunction "Pump wear"	
Wear caused by axial thrust on the shaft	Incorrect installation	Observe the installation information of the coupling manufacturer
	Unsuitable parts	use only an original combination part set
	See malfunction "Pump wear"	
Pump wear	Contaminated or wrong operating medium	Filter or exchange the operating medium, perform regular controls.

15 Technical data

For details about the technical data of your internal gear pump PGH.-3X, please refer to the technical data sheet "Internal gear pump, fixed displacement" RE 10227.

For the rated pressure of the internal gear pump, please refer to the information on the nameplate, see chapter 4.2 "Identification of the internal gear pump".

16 Appendix

16.1 Address directory

The addresses of our sales and service network can be found at www.boschrexroth.com/adressen

Bosch Rexroth AG
Hydraulics
Zum Eisengießer 1
97816 Lohr am Main, Germany
Phone: +49 (0) 93 52 - 18 0
Fax: +49 (0) 93 52 - 18 40
info.hydraulics@boschrexroth.de
www.boschrexroth.com